Tama Crédence

Carlo Colombo
2016



Madia in frassino tinto nero a poro aperto con parti metalliche laccate ottone satinato. Top in cristallo temperato 6mm e schienale interno in cristallo 6mm entrambi retroverniciati liquirizia brillante. Sullo schienale interno incisione a rombi. Ripiani interni in cristallo "grigio Italia" 8mm temperato e vassoi portaoggetti in legno. Dotata di luce interna LED attivata da un sensore all'apertura delle ante.

Cm (L x P x H)
240 x 48 x 72

Inches (L x P x H)
94½ x 19 x 28½

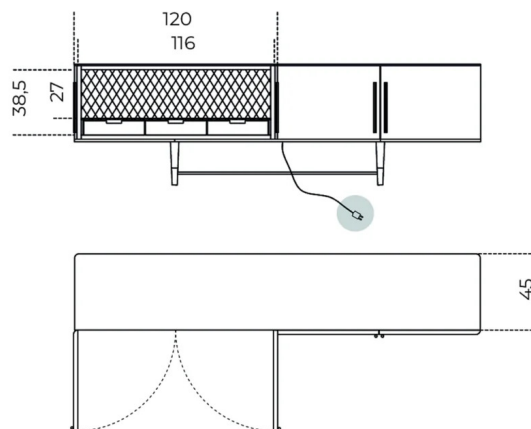
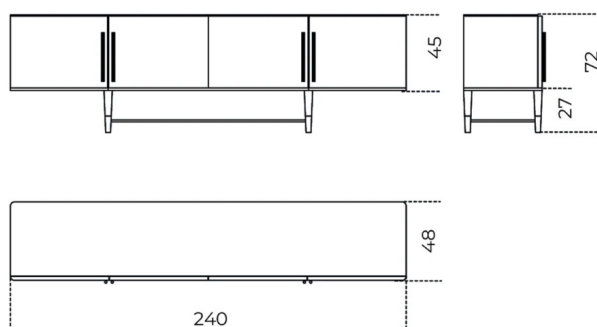

Finiture

Cristallo



"Grigio Italia"



Liquirizia brillante

Legno

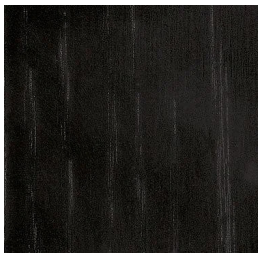

Frassino tinto nero a
poro aperto

Metallo



Laccato ottone satinato